



# HAM NEWS

NOVEMBER—DECEMBER 1958

In This Issue . . .

more

## GADGET RACK

Ideas . . . . . page 3

Also—

Scanning the Spectrum . . . . .	page 2
CHANNEL SPOTTER calibrator . . . . .	page 5
AUDIO PREAMP/LIMITER/PATCH . . . . .	page 6
1958 ALL-AMERICAN AWARDS . . . . .	page 8



Accessories in GADGET RACK above are (left to right): (1) Power control panel; (2) CHANNEL SPOTTER Calibrator; (3) CONEL MONITOR; (4) COMBO MONITOR Deluxe 1; (5) VOX-O-MATIC Voice Controlled break-in unit 1; (6) AUDIO PREAMP/LIMITER/PATCH; and (7) Signal input panel. Also in view—and coming in future issues—HAM-SCOPE-MARK II, High-C Band-switching VFO, 200-watt double sideband transmitter and plug-in Signal Slicer inside HRO-60 receiver.

Have a rack-mounted station? This GADGET RACK model, designed for relay-rack mounting—plus another table model and two handy accessories—continues the GADGET RACK series which began in the September–October, 1958 issue.

—Lighthouse Larry

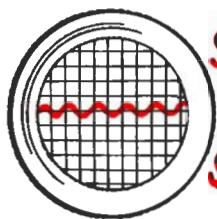

## SCANNING the SPECTRUM

### MEET THE DESIGNERS . . .

**K2PQF/4**—Robert V. Kinney, designed the **CHANNEL SPOTTER** calibrator and **AUDIO PREAMPLIFIER/LIMITER/PATCH** described elsewhere in this issue. Bob puts these gadgets—and a few other accessories in his gadget box—through their paces while operating his station on the phone amateur phone bands.

The **K2PQF/4** call sign indicates the recent transfer of Bob's department, the General Electric Communication Products Department's national headquarters, to Lynchburg, Va. from Syracuse, N. Y. He serves as na-

tional military communication sales manager for that operation, maker of our fine *Progress Line* of mobile two-way radio equipment.



**W9GFS**—Phillip E. Hatfield, constructed the clever **GADGET RACK** table model, **COMBO MONITOR** and **CONEL MONITOR** in the September–October, 1958 issue of *G-E HAM NEWS*, thus solving his station accessory problems. He also devised the relay rack type frame in this issue.

As you may surmise, Phil is an experienced constructor of his own equipment. His two mobile stations—entirely home-built, including complete receivers—incorporate innovations proven in more than twenty-five years of mobile hamming!

Vocationally, **W9GFS** is a technical data engineer with General Electric's Receiving Tube Department in Owensboro, Ky. So when Phil devotes a weekend to designing another gadget for his station, he's another of the thousands of radio hams who literally enjoy a "busman's holiday."

## new G-E SERVICE DESIGNED receiving tubes

High-reliability techniques—long famous in the production of General Electric's Five-Star and Computer tubes for critical applications—have been extended to include the most-used tube types in television and radio receivers. Thus, the expanded G-E SERVICE DESIGNED tube line now has many tube types found in amateur radio gear.

The principal improvements are:

- (1) "Snow-White" manufacturing processes to minimize short circuits between tube elements.
- (2) A new accelerated heater cycling test to insure proper tube performance under wide variations in line voltage.
- (3) A new G-E developed method of testing for shorts and opens.

(4) Building entertainment class tubes to meet life tests twice as rigid as Joint-Army-Navy specifications.

(5) A new method of applying uniform insulation coating on heater wire.

(6) Extending stiff military-type glass strain specifications to all SERVICE DESIGNED receiving tubes.

(7) Development of new materials, including a new anode permitting greater heat dissipation and longer life.

Many other improvements are being made on individual tube types.

Ask for the G-E SERVICE DESIGNED tubes listed below for when you need replacements for the tubes in your amateur gear.

1B3-GT	3CB6	5EU8	6AU6-A	6CD6-GA	6EU8	12AT7
1H2	3DT6	5U4-GB	6AX4-GT	6CG7	6EW6	12AU7-A
1J3	4BN6	5U8	6BK7-B	6CG8-A	6J6	12AX4-GTA
1K3	4BU8	5V3/5AU4	6BN6	6CL8-A	6SN7-GTB	12BY7-A
1X2-B	4BZ6	5Y3-GT	6BQ6-GA	6CX8	6T8-A	12BQ6-GA
2AF4-A	5AQ5	6AF4	6BQ7-A	6CY5	6U8-A	12DQ6-A
2CY5	5BK7-A	6AF4-A	6BU8	6DN7	6V6-GT	12SN7-GTA
3BN6	5CG8	6AL5	6BZ6	6DQ6-A	7EY6	17AX4-GT
3BU8	5CL8-A	6AQ5-A	6BZ7	6DT6	8CG7	17DQ6-A
3BZ6	5EA8	6AU4-GTA	6CB6-A	6EA8	8CX8	19AU4-GTA



## more **GADGET RACK** Ideas

A **GADGET RACK** frame—made from easily-worked aluminum angle and sheet—can be fitted into practically any type of relay rack or cabinet. The model shown is  $8\frac{3}{4}$  inches high, but could be any multiple of  $1\frac{3}{4}$  inches in height.

**THE AVAILABILITY** of aluminum angle stock in most hardware stores is a boon to the home constructor of radio equipment. A surprisingly strong **GADGET RACK** frame was fabricated from angle  $\frac{3}{4}$  x  $\frac{3}{4}$  of an inch in size with a  $\frac{1}{8}$ -inch-thick wall (Reynolds No. 7)—using ordinary hand tools. It shows no sign of sagging even with several pounds of power supply fastened to the rear panel.

Most constructional details show in the front and rear views of our model on this page. The assembly sketch, FIG. 1, illustrates how the pieces in the upper front corner joints overlap. The critical dimensions are marked on this diagram. Note that angle having 1-inch sides must be used if the minimum width between the relay rack uprights is between  $17\frac{1}{4}$  and  $17\frac{3}{4}$  inches.

Length of the side pieces will be dependent on the depth of the rack cabinet and the amount the power supply unit extends behind the frame.

**FLAT-HEAD MACHINE SCREWS** should be used to assemble all joints. Countersink all screw heads flush with the metal surface in order to clear the relay rack side rails.

The rear panel— $8\frac{1}{2}$  x  $17\frac{1}{4}$  x  $1/16$  of an inch thick on this model—is fastened to the frame with small angle brackets cut from the aluminum angle stock. Holes were punched in this panel for the row of accessory interconnection sockets. The sockets were then wired according to the schematic diagram (FIG. 1, page 3) in the last issue and connections were made to the power supply unit before it was fastened in place. Circuit for the power supply also is identical.

**THE POWER SUPPLY** was constructed on a  $1/16$ -inch-thick aluminum plate 4 x 15 inches in size. Corner posts of  $3/8$ -inch square brass rod 3 inches long drilled and tapped at both ends, fasten the plate onto the rear panel. Side and end plates were cut from  $1/16$ -inch-thick aluminum sheet, but perforated sheet or screening will provide more ventilation. Construction details are shown in the view on page 4.

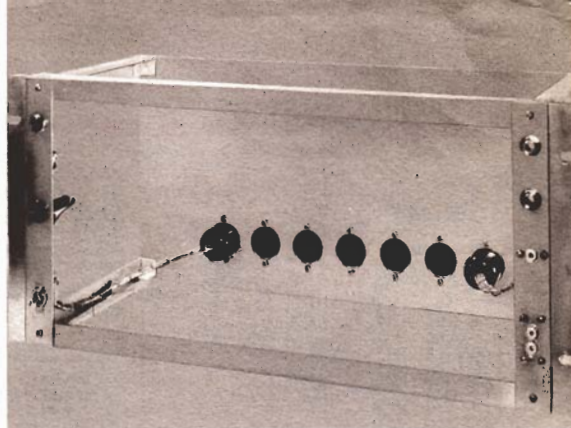

**RACK MODEL** of the **GADGET RACK** with most accessories removed. Socket at left on rear panel has eight contacts for power control panel; other sockets have eleven contacts for interconnection system between accessories. Signal input panel plugs into socket at right.

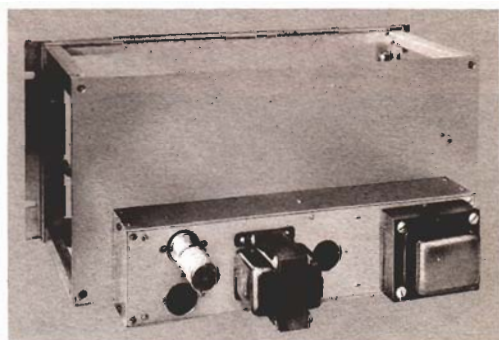

**REAR VIEW** of rack model, showing power supply fastened to rear panel. Socket between transformer and choke is for 5U4-GB rectifier. Power socket for external accessories is located below filter capacitor.

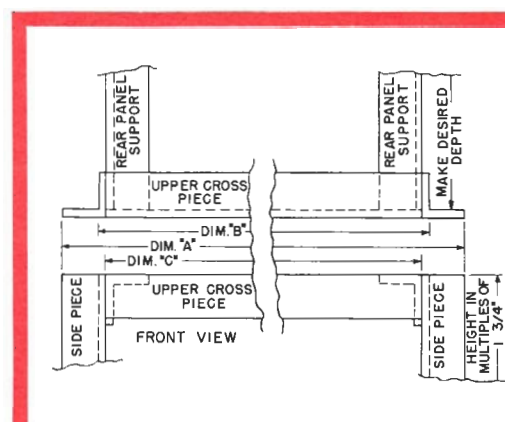

**FIG. 1.** SKETCH showing assembly of angles for sides, top and bottom, and rear panel supports. Table below gives dimensions.

Size of aluminum angle	1"	$\frac{3}{4}$ "
Dim. "A"—overall width	19"	19"
Dim. "B"—rack clearance	$17\frac{1}{4}$ "	$17\frac{3}{4}$ "
Dim. "C"—panel space	17"	$17\frac{1}{2}$ "

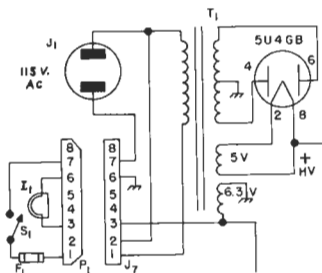
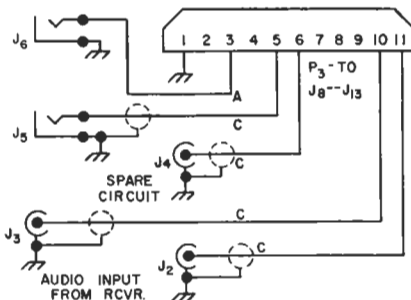

**FIG. 2. SCHEMATIC DIAGRAM** for power control unit and octal socket in power supply. See FIG. 1 (page 3) of the September-October 1958 issue for parts values, except for P<sub>1</sub> and J<sub>7</sub>.

TO SPEAKER  
VOICE COIL

TO RECEIVER  
HEADPHONE JACK

PICKUP ANT.  
INPUT



**FIG. 3. SCHEMATIC DIAGRAM** for signal input panel shown in front view, FIG. 1. Connectors J<sub>2</sub>, J<sub>3</sub> and J<sub>4</sub> are phonograph jacks; J<sub>5</sub> and J<sub>6</sub> are standard open circuit phone jacks. Or, use jacks which match type of plugs already used in your station.

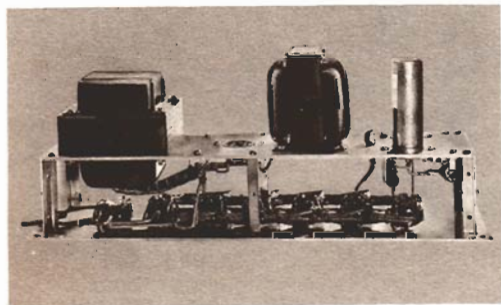

**POWER SUPPLY** constructed on plate-and-post type chassis 4 x 5 x 13 inches in size. Bus-bar interconnection sockets were fastened to separate plate and wired before assembly.



**REAR VIEW** of a table cabinet model GADGET RACK with power supply fastened to rear wall. Slot across rear of cabinet provides access to interconnection sockets from inside cabinet.

Of course, the power supply may be assembled with the components on the top deck, instead of extending rearward. A conventional chassis of similar proportions could then be used, with the accessory sockets mounted along the side wall facing forward. Other practical chassis are *Miniboxes*, or *Seezak* chassis plates and side rails.

**THE CABINET GADGET RACK** is adaptable to the rear-mounted power supply; the model below having been constructed to show this. Most utility cabinets have a slot about 2½ inches high extending across the rear wall. Thus, it is a simple matter to mount the accessory sockets on a plate large enough to overlap this opening by ¾ of an inch on all sides and fasten the power supply to it. The bottom surface of the power supply should be flush with the cabinet bottom or feet; otherwise the weight of the power supply may cause the cabinet to "rear up" when it is devoid of accessories.

In both the cabinet and relay rack models, accessories may be held in place with self-tapping screws driven into small holes drilled in the flanges above and below the front opening. Or, these holes may be drilled and tapped for machine screws. The latter method is preferable in the aluminum angle.

Our models will serve as a guide to planning a GADGET RACK tailored to your particular requirements. Conceivably, a unitized transmitter, receiver, or group of converters for the VHF bands could be assembled. But why say more; you may already have your GADGET RACK under construction!





# AUDIO PREAMPLIFIER/LIMITER/PATCH

NEED MORE AUDIO GAIN in your transmitter? If so, try this versatile unit which combines a preamplifier, level limiter and handy phone patch into a single package.

SOME TRANSMITTERS just don't have enough audio amplification to provide a highly readable phone signal under today's crowded amateur band conditions. This unit overcomes these problems with a tube lineup selected for desired characteristics in each circuit. In addition, a phone patch for all-important public service work is built in.

THE SCHEMATIC DIAGRAM, FIG. 1, shows a high-impedance microphone input at J<sub>1</sub>, coupled to the left-hand section of a 12AX7 twin triode. This tube has been designed to have a very low hum level. The output of this preamplifier drives a 6BA6 remote-cutoff pentode in the limiter. A second 6BA6 pentode is the automatic gain control tube. Negative bias for controlling the gain of the limiter stage is obtained by further amplifying the output signal in a 12AT7 twin diode and applying it to a 6AL5 twin diode. The bias is developed across the 1-megohm resistor and filtered by the .25-mfd capacitor shown just to the left of this tube.

This bias is applied to the number 3 grids of the 6BA6's and the right-hand section of

the 12AX7. This triode works as a DC amplifier and the variations in plate current cause the 0-1 DC milliammeter in series with the cathode to indicate the relative amount of compression.

The phone patch circuit utilizes a three-winding transformer from the vertical oscillator of a television receiver. The telephone line connects to the medium-impedance winding, the 6BA6 limiter to the highest-impedance winding, and the speaker voice coil circuit to the lowest-impedance winding. In position "1" of S<sub>1</sub>, the patch circuit and telephone line are not connected. In position "2," the patch operated only in one direction; it feeds the telephone signal into the amplifier. In position "3," the circuit operates as a two-way patch, also feeding the signal from the speaker circuit back to the telephone line.

CONSTRUCTION practice for this unit is pretty much the same as for the previous GADGET RACK accessories. The recommended layout for a plate-and-post type chassis is shown in FIG. 2. The unit also could be built on a 4 x 6 x 3-inch aluminum chassis with a panel 4 1/4 inches wide.

The only critical components are the phone patch transformer, T<sub>1</sub>, which should be kept away from power transformers to minimize

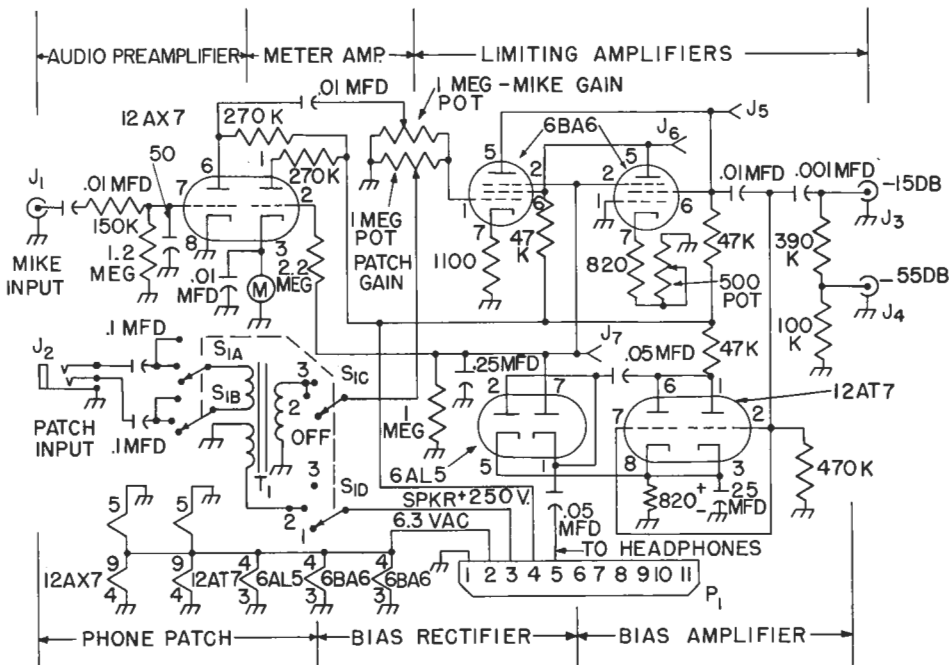

## CHANNEL SPOTTER

continued from page 5

**THE TUNEUP** is simply a matter of applying heater power to check that circuit, and, if okay, applying plate voltage. Turn  $S_1$  to the 100-KC position and check for signals at multiples of 100 kilocycles on a broadcast band receiver. A broadcasting station on one of these frequencies will serve as a standard for adjusting the oscillator to precisely 100 kilocycles by turning  $C_1$ . Or, tune 100-KC position and check for signals at in the 5-megacycle signal from *WWV* and adjust  $C_1$  until the fiftieth harmonic from the 100-kilocycle oscillator coincides with it.

Next, turn  $S_1$  to the 20-KC position and adjust the 2-megohm potentiometer until four signals can be counted between each 100-kilocycle marker signal on your receiver. Finally, if an oscilloscope is available, connect the

hum pickup; and the meter,  $M$ . The meter shown on page 1 has a flange only  $1\frac{3}{4}$  inches square, but the layout allows space for round or square meters having the standard body diameter of  $2\frac{1}{4}$  inches. A rotary tap switch can be substituted for the lever-action switch shown for  $S_1$  by drilling a hole  $\frac{3}{8}$  of an inch in diameter in place of the slot.

**CONNECTIONS** to this unit, other than those made through  $P_1$ , consist of a two-wire shielded lead from the telephone line to  $J_2$ ,

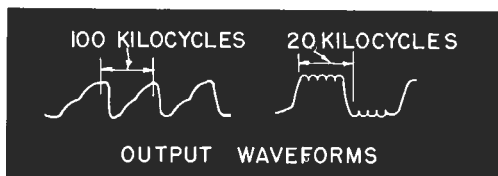

**FIG. 3. OUTPUT WAVEFORMS** which should be obtained at pin 10 on  $P_1$  when  $S_1$  is in (left) the 20-KC position; and (right) in the 100-KC position.

vertical amplifier to pin 10 on  $P_1$ , setting the horizontal sweep for two or three cycles on the screen. The waveforms for both 20- and 100-kilocycle signals should approximate those shown in FIG. 3.

If you already have a 100-kilocycle frequency standard, try adding the frequency divider stage to help spot that net frequency.

the microphone cord to  $J_1$  and a shielded single-conductor lead from  $J_3$  or  $J_4$  to the transmitter audio input. Proper settings for the *MIKE GAIN* and *PATCH GAIN* controls is best determined by experiment. The 500-ohm potentiometer in the cathode of the second 6BA6 controls the compression level. It should be set to the highest resistance that does not result in the microphone picking up an objectionable amount of background noise in the radio shack.

**FIG. 1. SCHEMATIC DIAGRAM** for the combination audio preamplifier/limiter/phone patch unit. All resistances not otherwise marked are  $\frac{1}{2}$ -watt power rating; all capacitance values not otherwise marked are in mmf. Potentiometers should have a  $\frac{1}{2}$ -watt rating.

**NOTE:** If the Merit A-3001 vertical oscillator transformer is used for  $T_1$ , connections should be made as follows: Brown and black leads to  $J_2$ ; red and blue leads to the *PATCH GAIN* potentiometer; and the yellow and green leads to the speaker circuit. Other standard transformers may have the same color-coding on leads.

### PARTS LIST

- $J_1$ .....female connector to fit microphone plug.
- $J_2$ .....3-circuit phone jack.
- $J_3, J_4$ .....midget phono type jacks.
- $J_5, J_6$ .....insulated phone tip jacks.
- $M$ .....0-1 DC milliammeter,  $1\frac{3}{4}$ -inch flange,  $1\frac{1}{2}$ -inch-diameter body (Lafayette TM-11 shown on model G.E. type DW-91 also suitable).
- $P_1$ .....11-prong male octal plug (Amphenol 86-PM11).
- $S_1$ .....4-pole, 3-position, non-shorting lever action switch (Mallory 6243; or use equivalent single section rotary tap switch).
- $T_1$ .....three-winding vertical output transformer (Merit A-3001, or equivalent).

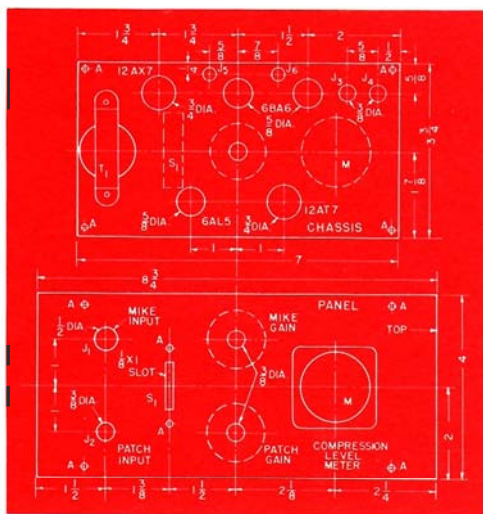

**FIG. 2. PANEL-CHASSIS LAYOUT** diagram. The panel plate is viewed from the front; chassis plate from the rear. Drill mounting holes to match feet on  $T_1$  and locate it between the plates if possible. Holes marked "A" are for corner posts, which should be 3 inches long, tapped at both ends.



**THREE SMILING RADIO AMATEURS**, shown above just after receiving their trophies and checks for \$500 at the 1958 ALL-AMERICAN AWARDS presentation, are: Vernon Townsend, W9YCY; Wayne Lemons, KOCEC; and Albert Kazukonis, ex-W1OBZ.

Townsend, of Menomie, Wis., while serving as Dunn County RACES Radio Officer, quickly organized emergency communications and operated his mobile station steadily for three days after a tornado devastated Western Wisconsin last June.

Lemons, of Buffalo, Mo., has conducted extra-curricular courses in electronics at several schools in Missouri, in addition to civic activities in the Little League, Boy Scouts and other youth groups; and Rotary and other community service agencies. Kazukonis, Brockton, Mass., has aided technical programs in schools through donations of supplies, taught radio classes, and promoted better business ethics as an official of the Brockton chapter of the Electronic Technicians Guild of Massachusetts.

## 1958 ALL-AMERICAN AWARDS

### THREE RADIO AMATEURS

*are among ten electronics technicians honored for outstanding community service in 1958.*

Thirteen radio amateurs were among the candidates for the 1958 Awards. Three were winners; another, Henry Falconio, W9OIL, was awarded an honorable mention plaque. The others, who received certificates of commendation, are: W1AD, W3DYE, W3SCT, W6QPF, W7JMM, KN8LLA, K9IEY, WØIRM, and WØZVD.

The ALL-AMERICAN AWARDS program, to honor electronics service technicians who have distinguished themselves through community service, is sponsored annually by General Electric's Receiving Tube Department in Owensboro, Ky.

NOVEMBER—DECEMBER, 1958

VOL. 13—NO. 6

Available FREE from your  
G-E Tube Distributor



E. A. Neal, W2JZK—Editor

published bi-monthly by

ELECTRONIC COMPONENTS DIVISION

GENERAL  ELECTRIC

Schenectady 5, N. Y.

Copyright 1958, General Electric Co.

DES. J. BERTS  
2460 MT. VERNON STREET  
LYNN, MASSACHUSETTS